

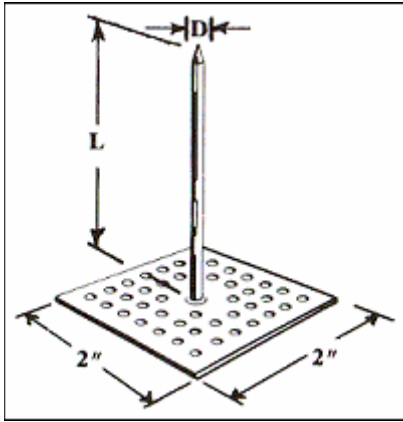

Insulation Hangers



PERFORATED BASE
(ADHESIVE REQUIRED)

PERFORATED HANGER SPECIFICATIONS	
"D"	"L"
12 GA (.105)	3/4 " minimum 16" maximum

- Nail : Low Carbon Steel, copper coated. (Aluminum and Stainless Steel nails available on special order.
- ANNEALING : All steel pins are fully annealed unless otherwise specified.
- BASEPLATE : Low Carbon Steel, galvanized.
- ACCESSORIES : Self locking washers in a variety of sizes, shapes and materials.

Self-Locking washers 10-12-14 Gauge

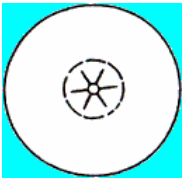

R-200

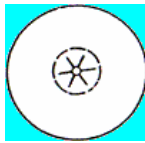

R-175

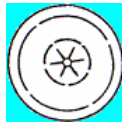

R-150

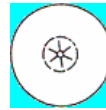

R-120



R-100



S-125



S-150

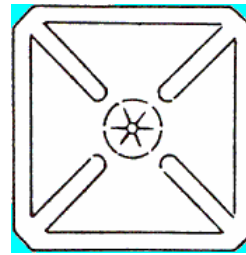

S-250

SELF LOCKING WASHERS SPECIFATION					
TYPE	S-250	S-150	S-125	R-175	R-150
Size or diameter	2 1/2" x 2 1/2"	1 1/2" x 1 1/2"	1" x 1 1/4"	1 3/4"	1 1/2"
Thickness	.06	.016	.016	.016	.016
Material	Mild Steel	Mild Steel	Mild Steel	Mild Steel	Mild Steel
Plating	Galvanized	Galvanized	Galvanized	Galvanized	Galvanized
Edge	Beveled	Beveled	Beveled	Flat	Beveled
Other materials available	Alum.,S.S.	Alum.,S.S.	Alum.,S.S.	Alum.,S.S.	Alum.,S.S.