

Installation Method

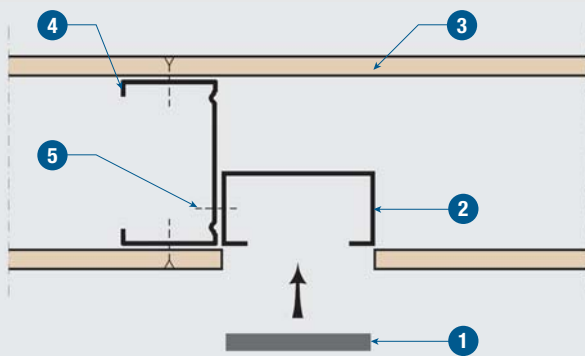

Detail 1 Inserting switchbox in fire rated dry walls

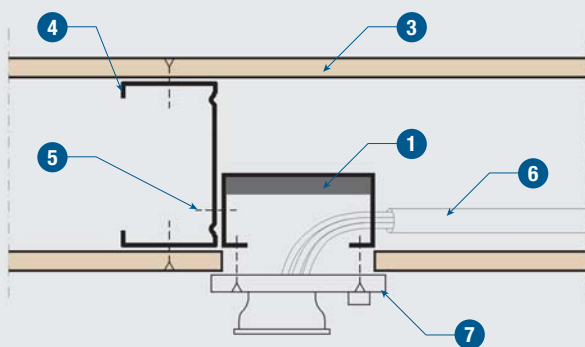

Detail 2 Application in fire rated dry walls (1-sided)

Compartment walls form a fire barrier between the areas they separate. Often, however, recessed switchboxes need to be installed in fire rated dry wall structures. The recessed installations then jeopardise the fire barrier function of the compartment wall.

Standard switch boxes compromise the fire resistance of fire rated walls. PROMASEAL® Switchbox Intumescent provides the fire resistant performance to maintain the fire resistance of the compartment wall in which they are installed.

TECHNICAL DATA

2 hours fire rating, integrity in accordance with the criteria of BS 476: Part 20.

- 1** PROMASEAL® Switchbox Intumescent in modules of 70mm x 70mm x 8mm thick
- 2** Electrical switch box in steel 72mm x 72mm x 35mm
- 3** Fire rated steel stud partition
- 4** Steel studs
- 5** Fixings
- 6** Electrical wiring
- 7** Switch box and socket outlets

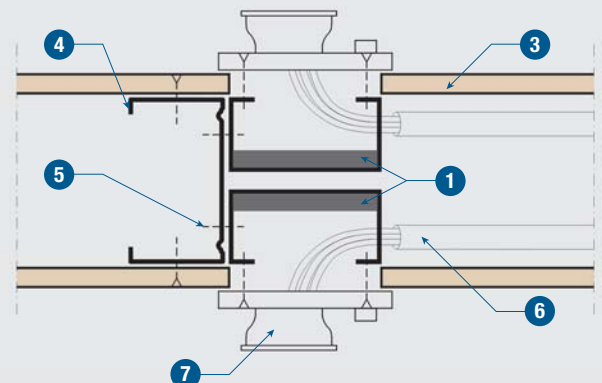

Detail 3 Application in fire rated dry walls (2-sided)