

Uniclass	L68111	Epic	F811
Cl/SfB		Ry	(K2)

Promat



**PROMASEAL® FyreStrip (High Compression Expansion Strip)
Seals for Movement Joints in Floors/Walls**



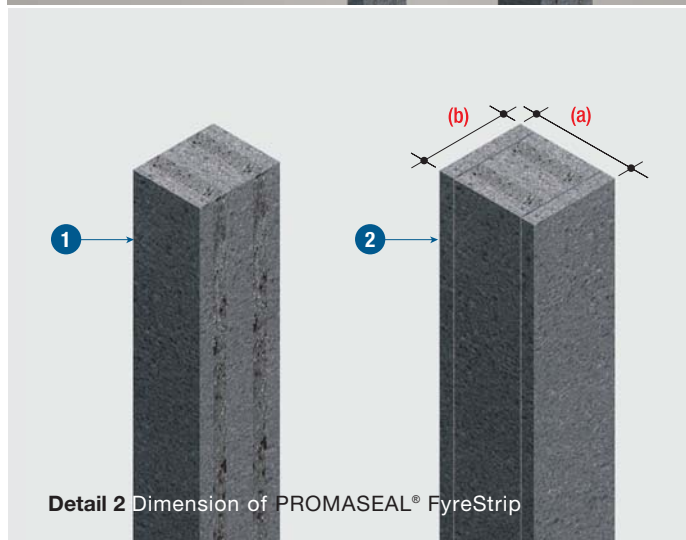
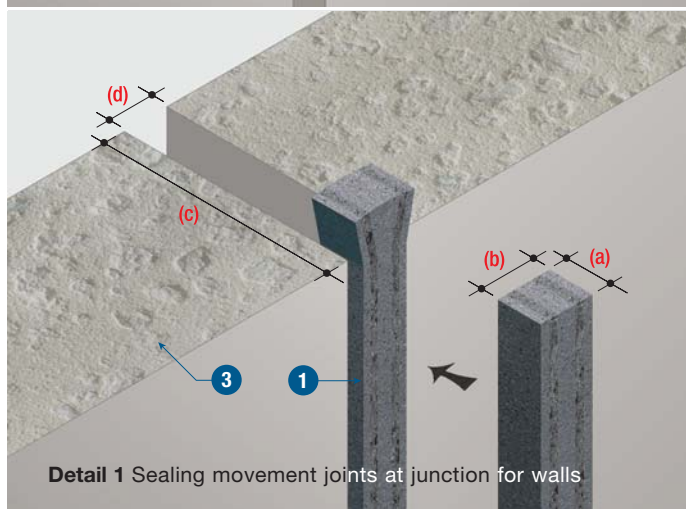
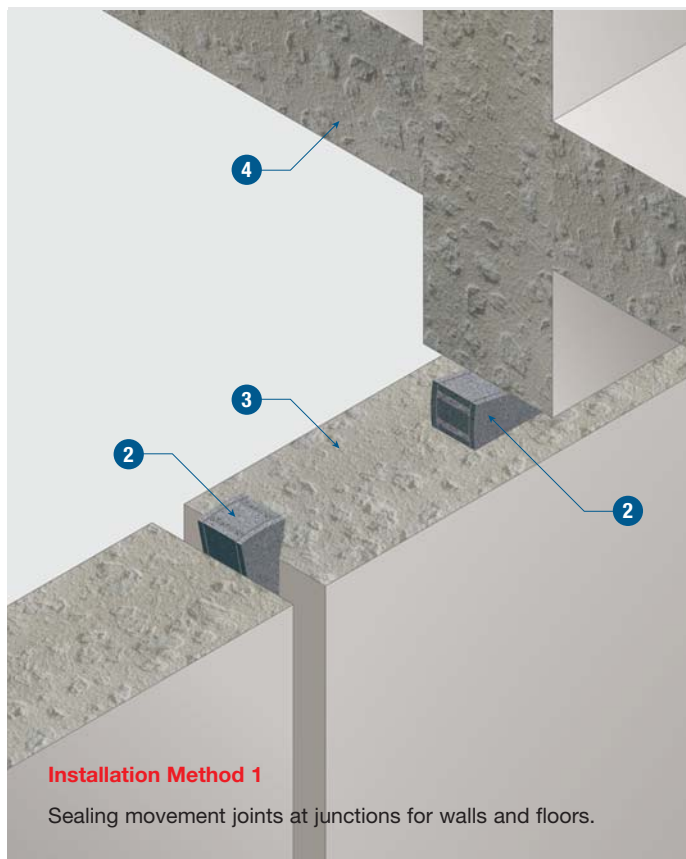

TECHNICAL DATA

4 hours fire rating, integrity in accordance with the criteria of BS 476: Part 20.

- 1 PROMASEAL® FyreStrip, integrity only version without cover strip
- 2 PROMASEAL® FyreStrip, insulated version with cover strip
- 3 Wall element with fire resistance ≥ 4 hours
- 4 Floor with fire resistance ≥ 4 hours

For lower fire ratings, the thickness of the building element may well be less than specified below:

Product code	FS20 (mm)	FS40 (mm)	FS50 (mm)	FS80 (mm)	FS100 (mm)
(a) Product depth	50	50	50	80	100
(b) Product width	28	46	56	84	124
(c) Min. element thickness	170	170	170	170	170
(d) Min. gap width for strip insertion	16	24	32	48	64
Min. gap width at full compression	12	16	24	36	44
Max. gap width at full expansion	20	40	50	80	100

NOTE: For joints at the top of hollow block and cavity walls, the cavity must be sealed for a minimum of one course.

In 2-hours framed walls, 2 hours fire rating can be achieved in joints up to a maximum of 50mm sealed with FS50.

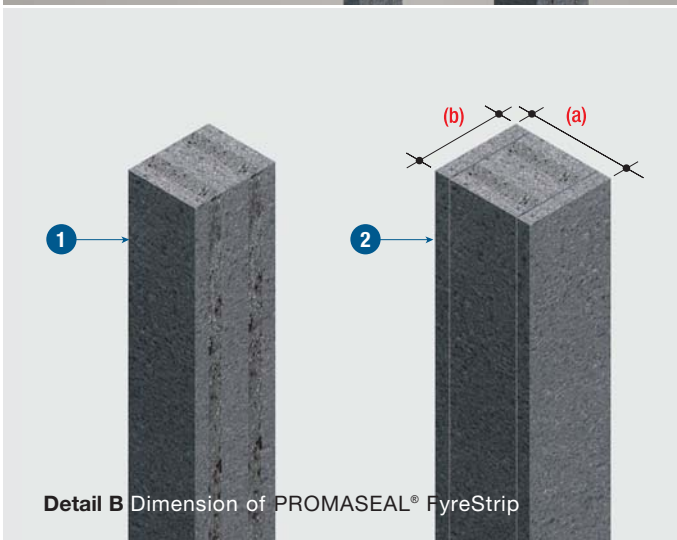
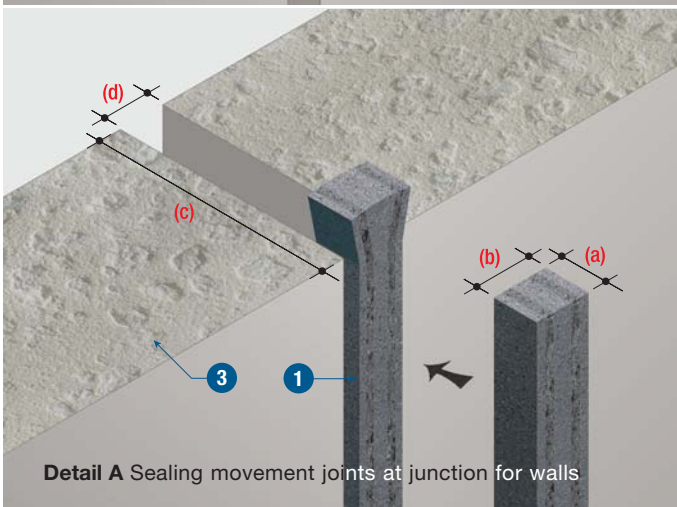
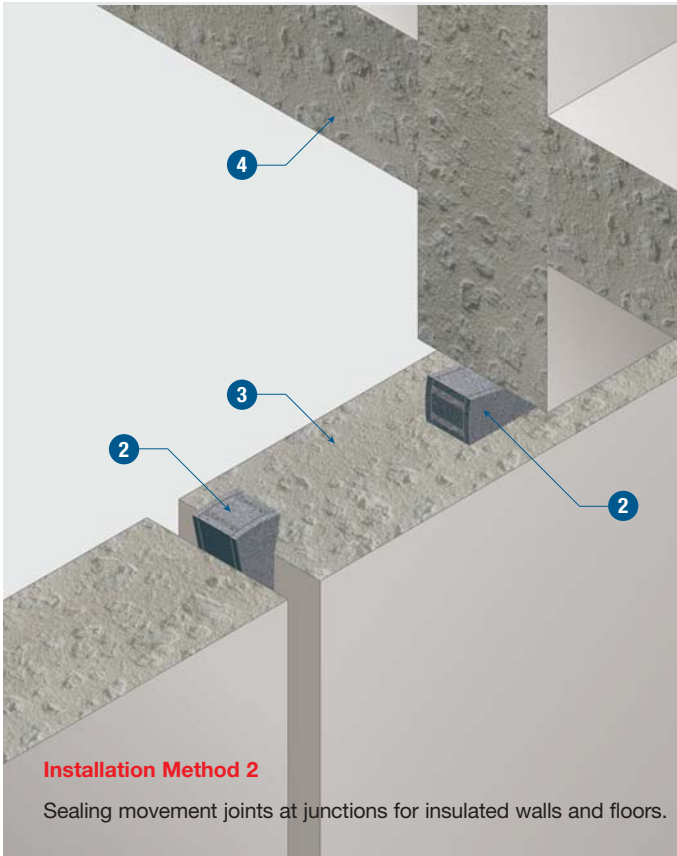

TECHNICAL DATA

Up to 4 hours fire rating, integrity and insulation in accordance with the criteria of AS 1530: Part 4, AS 4072: Part 1 and BS 476: Part 20.

- 1 PROMASEAL® FyreStrip, integrity only version without cover strip
- 2 PROMASEAL® FyreStrip, insulated version with cover strip
- 3 Wall element with fire resistance ≥ 4 hours
- 4 Floor with fire resistance ≥ 4 hours

For lower fire ratings, the thickness of the building element may well be less than specified below:

Product code	FS20 (mm)	FS40 (mm)	FS50 (mm)	FS80 (mm)	FS100 (mm)
(a) Product depth	90	90	90	100	120
(b) Product width	28	46	56	84	124
(c) Min. element thickness	170	170	170	170	170
(d) Min. gap width for strip insertion	16	24	32	48	64
Min. gap width at full compression	12	16	24	36	44
Max. gap width at full expansion	20	40	50	80	100

NOTE: For joints at the top of hollow block and cavity walls, the cavity must be sealed for a minimum of one course.

In 2-hours framed walls, 2 hours fire rating can be achieved in joints up to a maximum of 50mm wide sealed with FS150.

PROMASEAL® FyreStrip is a compressible, flexible, fire resistant seal which is used where movement joints are formed in the structure of building. It consists of layers of PROMASEAL® Grafitex intumescent material bonded to special foam and has been successfully fire tested up to 4 hours in joints within masonry walls and floors.

The strips are ideal for sealing movement joints at junction between compartment walls and floors. Their flexibility makes them suitable for use in a variety of configurations. The fire performance of PROMASEAL® FyreStrip will vary according to the particular application. In addition the width of the gap into which the strip will be inserted as well as their orientation will have effect on the level of protection provided.

The strip thickness is determined by the minimum and maximum positions of the gap width expected during the life of the building. The strip thickness should not be less than the maximum expected width (see the charts on pages behind). It is important to insert the strip so that the Grafitex sits parallel to the direction of movement.

One end of the appropriate size of PROMASEAL® FyreStrip is simply compressed between fingers and thumb until it can be inserted into the required gap. The Strip can then be progressively pushed in to the joint. If it is difficult to insert, the strip may be knocked in to place with a hammer handle, rubber mallet or by placing a piece of timber along the length of the Strip and knocking the timber. It is advisable to insert each Strip progressively along it's length.

For joints at the top of hollow block & cavity walls the cavity must be sealed for a min. of one course. The strip must be centrally located in the wall or floor joint. In cold conditions it is advisable to store in a warm atmosphere immediately prior to installation as this improves compressibility.

The strip may readily be cut to suit a particular length. When more than one length of PROMASEAL® FyreStrip is required in a joint, ensure the two pieces are butted tight together and there is no gap between the adjoining ends. At the ends of each joint, ensure the strip is fitted tight to the adjoining surface.

If a smoke or water seal is required, apply a suitable sealant according to the manufacturer of the sealants instructions.

PROMASEAL® FyreStrip is non load bearing. If the area where the FyreStrip is installed is trafficable a suitable plate should be fixed over the joint, always allowing for movement.

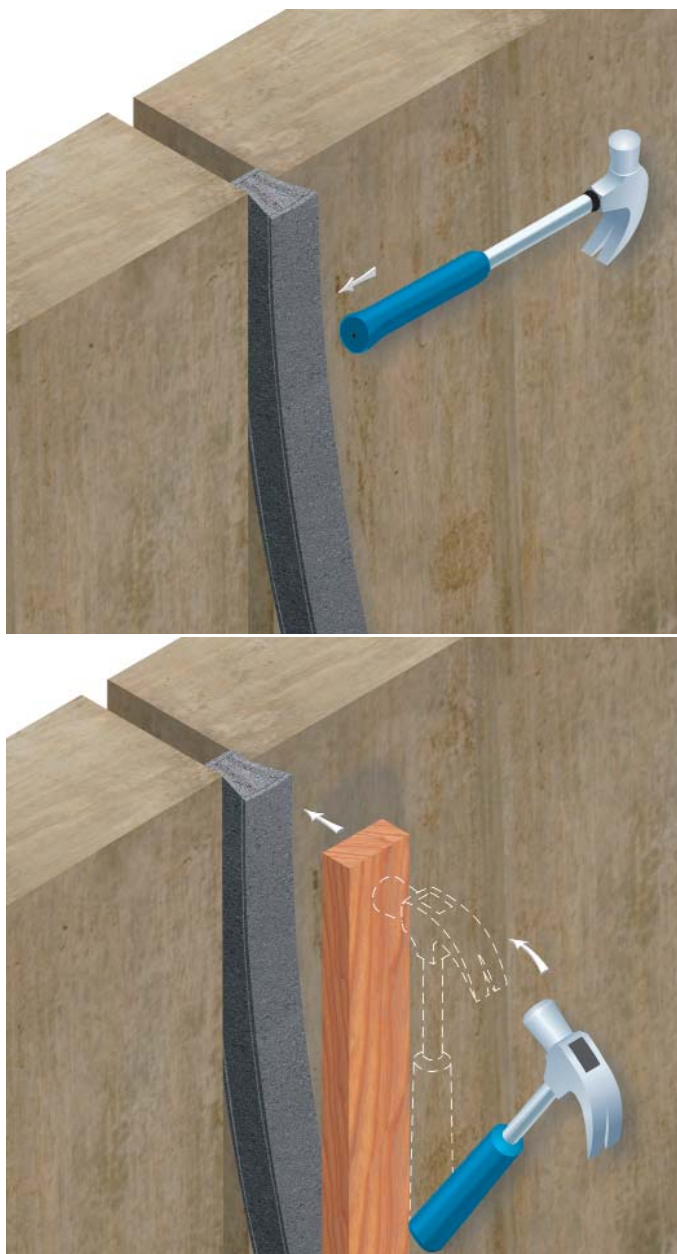

Important Notes

Promat product data sheets and health and safety data sheets are regularly reviewed and are available on request. The successful use of this product is dependent on a number of factors. As the information contained in this literature can only be of a general nature, it is advisable to consult our technical department if there is any doubt about the correct use of this product in a particular application. Our technical representatives and advisors are available to provide further technical and commercial assistance.

PROMASEAL® FyreStrip is manufactured under a quality management system certified in accordance with ISO 9002.

ASIA PACIFIC HEADQUARTERS

Promat International (Asia Pacific) Ltd.
Tel: +60 (3) 6250 2880
Fax: +60 (3) 6250 1159
Email: info@promat-ap.com

AUSTRALIA

Sydney
Promat Australia Pty. Ltd.
Tel: +1 800 30 20 20
Fax: +61 (2) 9630 0258
Email: mail@promat.com.au

Adelaide
Promat Australia Pty. Ltd.
Tel: +1 800 30 20 20
Fax: +61 (8) 8352 1014
Email: mail@promat.com.au

Melbourne
Promat Australia Pty. Ltd.
Tel: +1 800 30 20 20
Fax: +61 (3) 9645 3844
Email: mail@promat.com.au

CHINA

Guangzhou
Promat China Ltd.
Tel: +86 (20) 8136 1167
Fax: +86 (20) 8136 1372
Email: promat@public.guangzhou.gd.cn

Promat South China
(Division of Promat China Ltd.)
Tel: +86 (20) 8136 1167
Fax: +86 (20) 8136 1372
Email: promat@public.guangzhou.gd.cn

Beijing
Promat North China
(Division of Promat China Ltd.)
Tel: +86 (10) 6460 4851
Fax: +86 (10) 6460 5297
Email: promat@95777.com

HONG KONG
Promat International (Asia Pacific) Ltd.
Tel: +852 2836 3692
Fax: +852 2834 4313
Email: apromath@netnavigator.com

INDIA

Promat Representative Office
Tel: +91 (11) 2469 1594
Fax: +91 (11) 2469 2064
Email: raman@promat.com.my

MALAYSIA

Promat (Malaysia) Sdn. Bhd.
Tel: +60 (3) 6250 2880
Fax: +60 (3) 6250 1158
Email: promat@po.jaring.my

PHILIPPINES

Promat Representative Office
Tel: +63 (2) 772 3675
Fax: +63 (2) 772 3617
Email: promat-remar@qinet.net

SINGAPORE

Promat Building System Pte. Ltd.
Tel: +65 6294 9689
Fax: +65 6294 9783
Email: promavic@singnet.com.sg

OFFICIAL WEBSITE

www.promat-ap.com

Your local Promat Supplier

